

Hookup Diagram

Instrument wired STEREO

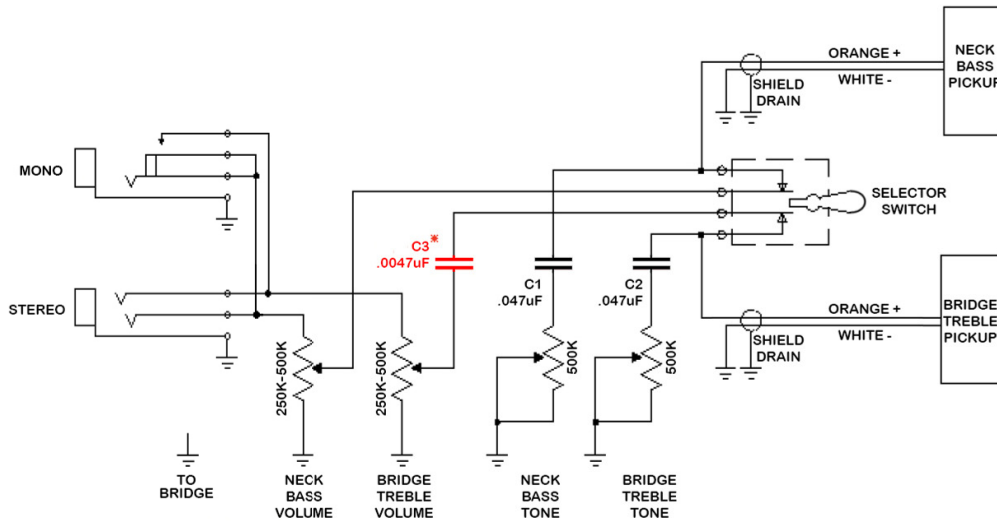

* If capacitor C3 is present in your instrument wiring it will greatly reduce the output volume of the TREBLE pickup.

Many prefer to jumper or remove this capacitor



Classic Rick Pickups

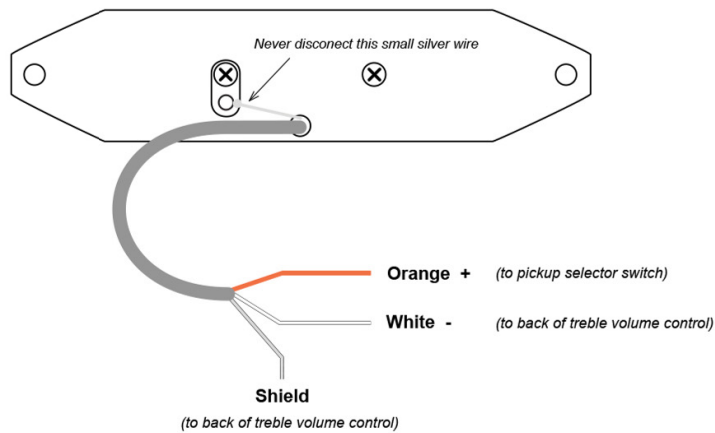

ORANGE wire is normally the HOT (+) wire
 WHITE wire is normally the NEUTRAL (-) wire which goes to ground
 SILVER wire (Drain) always goes to GROUND on the instrument

The ORANGE and WHITE wires are provided separately in case you desire to use a phase switch, or if you find your pickups are out-of-phase.



Classic Rick Pickups